

nova

Embeddable Maturix® Sensor for
Temperature and Strength Monitoring

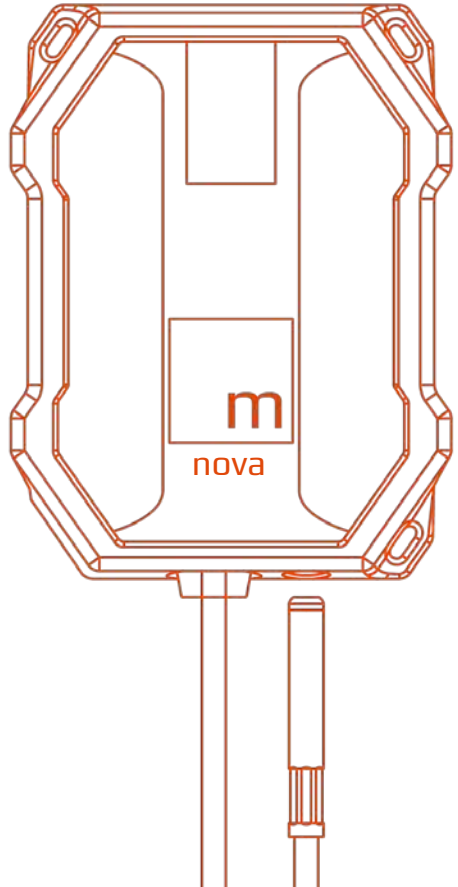

Quick Start Guide

Manufactured by **Maturix**[®]

CVR-nr 36424540

Thomas B.Thriges Gade 42, st.

5000 Odense C

Denmark

About this guide

This Quick Start Guide covers the most fundamental product information and instructions for using the Nova and Maturix® solution. For additional documentation and information, please visit maturix.com/help.

About Maturix®

Maturix is a smart system for monitoring the concrete curing process. It is one of the most advanced solutions for wireless concrete monitoring, trusted by leading companies within the construction industry worldwide. Read more at maturix.com.

Disclaimer

Information in this guide is based on specifications believed correct at the time of publication. The right is reserved to make changes as design and general improvements are introduced. Find the latest version in the Help Center at maturix.com/help.

Introduction

The Nova is a powerful yet easy-to-install sensor for monitoring temperature, maturity, and in-place strength in concrete structures. It features two monitoring points - one inside the device and another at the tip of its 0.5m cable.

Once the cable tip is removed, the Nova starts measuring and storing data every 15 minutes using precise digital sensors. With low power consumption and ample internal storage, it operates for over 150 days, capturing data from the concrete pour to ensure quality documentation.

A durable rubber cover protects the device from impact during installation and features three mounting points for secure attachment to rebars. All data is stored internally and can be accessed via the Maturix Nova App for real-time insights into temperature, maturity, and strength.

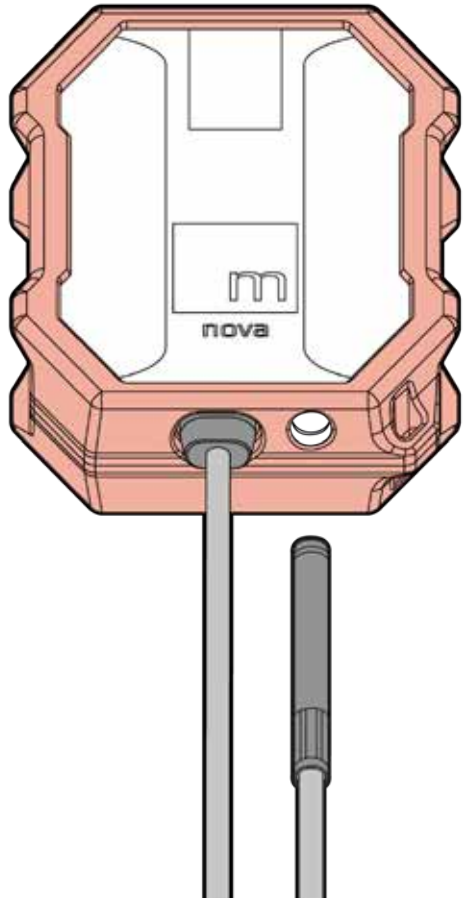

Product diagram

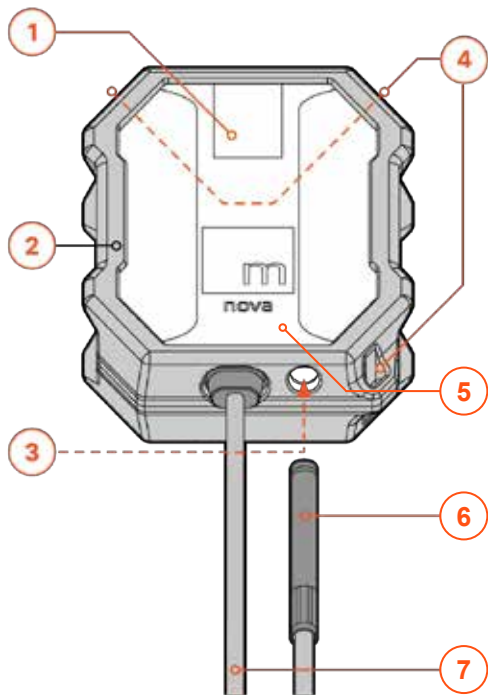

- 1 Sensor ID
- 2 Shock-absorbing cover
- 3 Activation LED
- 4 Mounting points
- 5 Internal temperature sensor
- 6 External temperature sensor
- 7 1.5m (5ft) + 3m (10ft) cables

Getting started

To use the Nova, you need an iOS or Android device with Bluetooth. Install the Maturix Nova app and configure the Nova with the pour information. Any configuration (name, concrete mix etc.) as well as all data recorded by the device will be stored on the Nova.

Download and install Maturix® app

To download the Maturix Nova app, please go to the App store or Play store and search 'Maturix' or scan the QR codes.



Scan the QR to download the the **Maturix® Nova App**

Sign up or log in to the app



The screenshot shows a 'Log in / Sign up' screen. It has a text input field labeled 'Enter your email' with an '@-mail' icon. Below the field is an orange 'Log in' button.

Sign in/create an account by entering your email



Check your inbox for a verification code



The screenshot shows a 'Welcome to Maturix!' screen. It has a text input field labeled 'Enter the pin we sent to john@construction.com'. Below the field are four empty input boxes for the pin. At the bottom are 'Cancel' and 'Log in' buttons.

Enter the code to get started!

Operation

Activating / deactivating the Nova

Activating the Nova

To activate the Nova, remove the cable tip from the body of the device.

The activation LED will start blinking, the Nova will start monitoring and be discoverable in the Maturix Nova app under 'Nearby devices'. The LED be active for 15 minutes after activating the Nova.

Deactivating the Nova

To deactivate the Nova and put it in standby, input the cable tip into the body of the device.

After 60 seconds the Nova will go into standby mode and clear the measurements. If the Nova has been configured, it will keep the configuration.

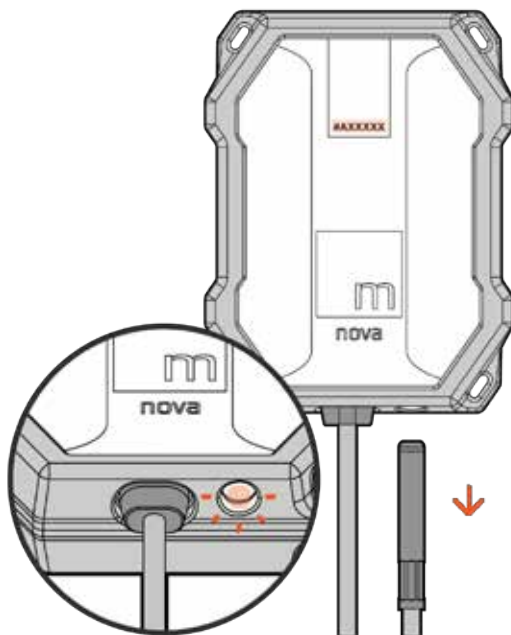

Discovering nearby devices

In the app, go to 'Nearby Devices' to view all devices detected by your phone.

The device will periodically scan for new devices and display them on a list as they are discovered.

To restart the scan, tap the scan button in the top right corner.

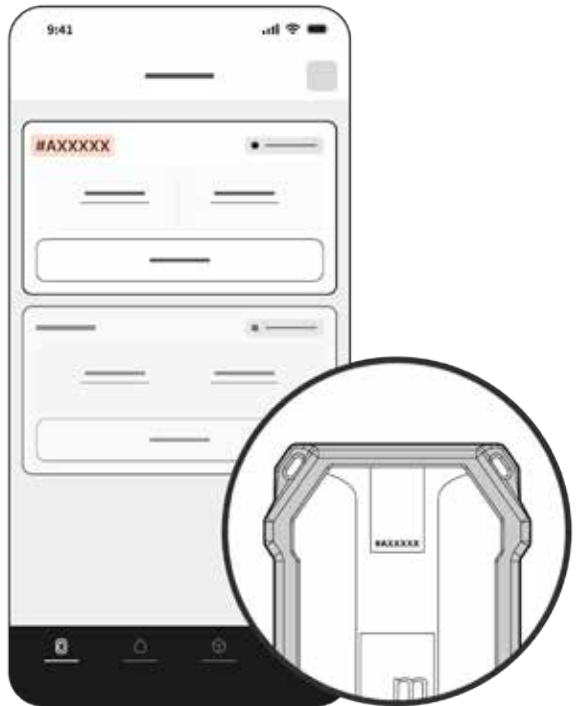

Mount the Nova securely to the rebars

Use the mounting points and cable ties to mount the Nova secure to the rebars making sure that the logo is facing upwards for best signal.

Secure the cable along the rebars until it is positioned in the desired position.

Attention:

For best signal strength to the Nova after the concrete has been placed, keep the cover layer to a minimum.

The closer the Nova is to the surface, the better the signal. For optimal performance, keep the cover layer under 5 cm.

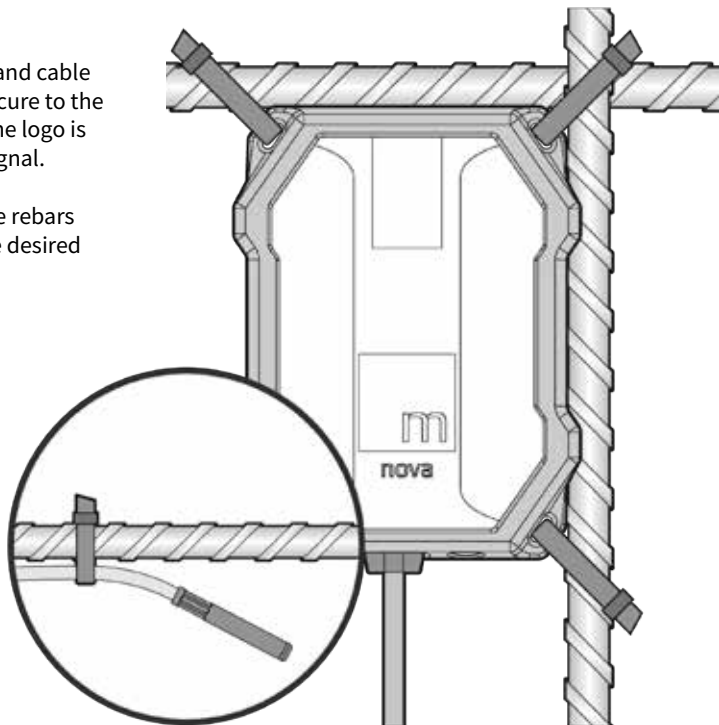

Top view of installation on rebars using cable ties

Configuring and starting the pour

Once the device is turned on and visible under 'Nearby Devices,' you can set it up with all the necessary pour details. Additionally, you have the option to assign a concrete mix from your saved library.

All configuration settings will be transferred to the Nova, ensuring that the data is stored and can be accessed by you or any other user.

If the device is deactivated by reinserting the cable, the configuration will remain saved on the Nova. This feature allows you to prepare the setup in advance, turn off the device, and then reactivate it when installing it into the structure.

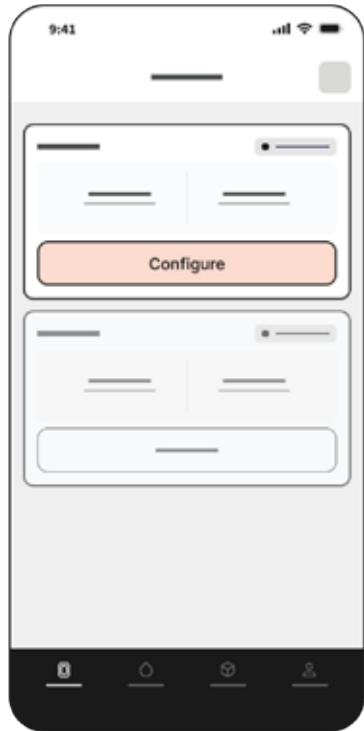

Troubleshooting

Problem	Possible cause	Solution
'No nearby devices'	App not able to scan on Bluetooth	Toggle Bluetooth off and on
		Restart the application
		Restart your mobile device
	Bluetooth is not enabled on the smartphone	Verify Bluetooth settings
	The Nova is inactive	Ensure the device is powered on and discoverable
Trouble connecting to the device	The device might be out of Bluetooth range	Move closer to the device
	The app is experiencing issues with Bluetooth connectivity on the smartphone	Restart the application
		Restart your mobile device

Problem	Possible cause	Solution
Trouble connecting to the device	There are Bluetooth-related issues on the smartphone	Toggle Bluetooth off and on
	Bluetooth is not turned on the smartphone	Verify Bluetooth settings
	The Nova has not been activated	Ensure the device is powered on and discoverable
	The smartphone does not support Bluetooth 5.x	Attempt to connect using a different mobile device
The device is not activating	The device is already active, but the LED activation window has expired	Insert the cable tip into device and wait +60 seconds - after remove the tip and look for LED
The LED is not blinking	The device is already active, but the LED activation window has expired.	Attempt to re activate the device
	The battery may be faulty	Contact Maturix support

Problem	Possible cause	Solution
Cable showing is showing an 'error' notification	The cable could be damaged	Check for cuts/damage



Designed in Denmark

©2025 Maturix
All rights reserved

www.maturix.com

